

Hybrid cooler HBR Series

HBR
Series

Hybrid cooling towers HBR series

The closed circuit cooling towers can be also supplied in HYBRID version. That is a tower that can work both in evaporative (wet) and in dry mode depending on the ambient temperature or on the temperature of the fluid to be cooled. With the HYBRID system (MITA HBR models) the water and/or the energy consumption can be optimized or considerably reduced.

HBR takes advantage of the evaporative efficiency only when it is necessary, so that the fluid can be cooled to a temperature that is very close to the wet bulb temperature (wet mode). Alternatively, it takes advantage of the efficiency of the air cooling in order to achieve a fluid temperature close to the ambient dry bulb temperature (dry mode).

Distinguishing features:

- Unique design: Peculiar geometry and position of the two heat exchangers. They are easily accessible for maintenance operations
- Extremely reduced consumptions: the HBR cooler is designed to "consume" the bare minimum in terms of water and energy. Within the space of a year it takes advantage of the most appropriate type of cooling depending on the actual climatic conditions
- Maximum efficiency of wet function (summer): The fluid flows inside the smooth tubes heat exchanger and it is cooled by evaporation. The finned tubes' coils are in stand-by
- Maximum efficiency of dry function (winter): The fluid flows inside the finned tubes heat exchangers and it is cooled by air. The smooth tubes' coil is in stand-by. Only the necessary energy for the air circulation through the finned coils is consumed.
- Cost-effective control: The system is electronically controlled by a PLC. The cabinet can be supplied pre-wired (in the factory) on the unit's casing or it can be provided by the customer.
- Long working life: Naturally corrosion-free materials resistant over time. Solutions to simplify and speed up maintenance operations.

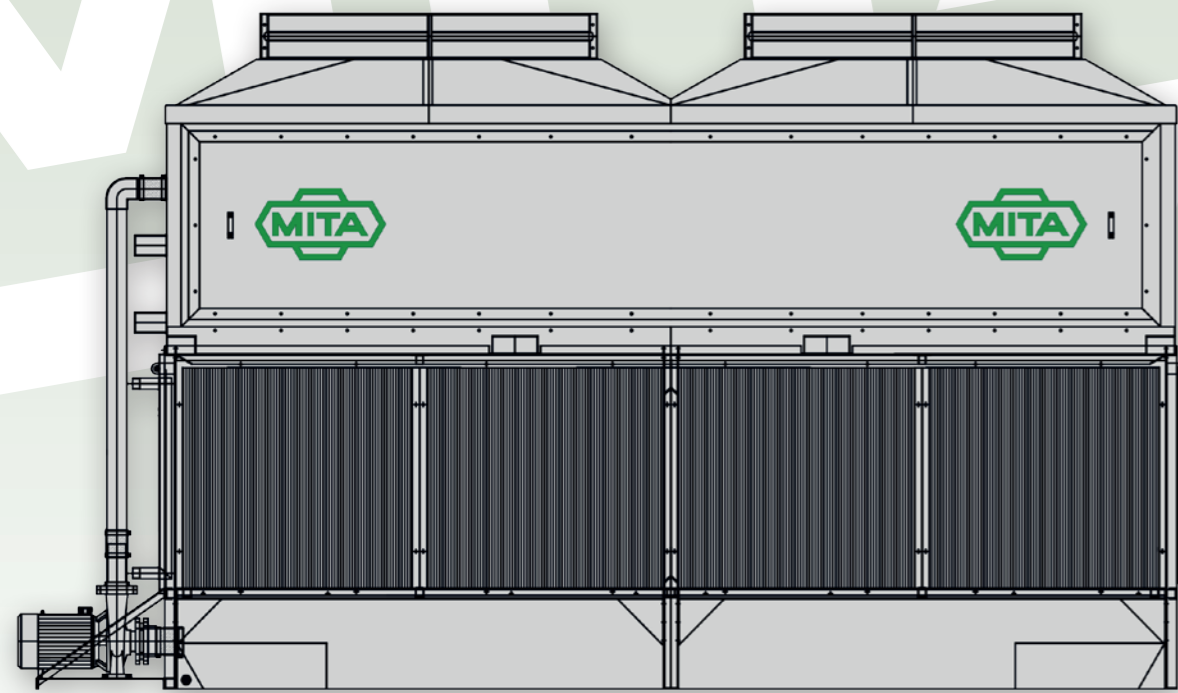

Hybrid cooler HBR Series

HBR
Series

The peculiarity of HBR coolers is that they are equipped with two separate circuits:

- One or more wet heat exchanging coils made of smooth, hot dip galvanized tubes located inside the unit's casing.
- Two dry heat-exchanging coils made of copper tubes and fins in aluminum located on the air inlet openings, outside the unit.

SUMMER Evaporative function (wet mode)

- The fluid to be cooled flows inside the smooth tubes coils
- The spraying pump is ON
- Axial fans in suction mode
- Finned tubes coils in stand-by.

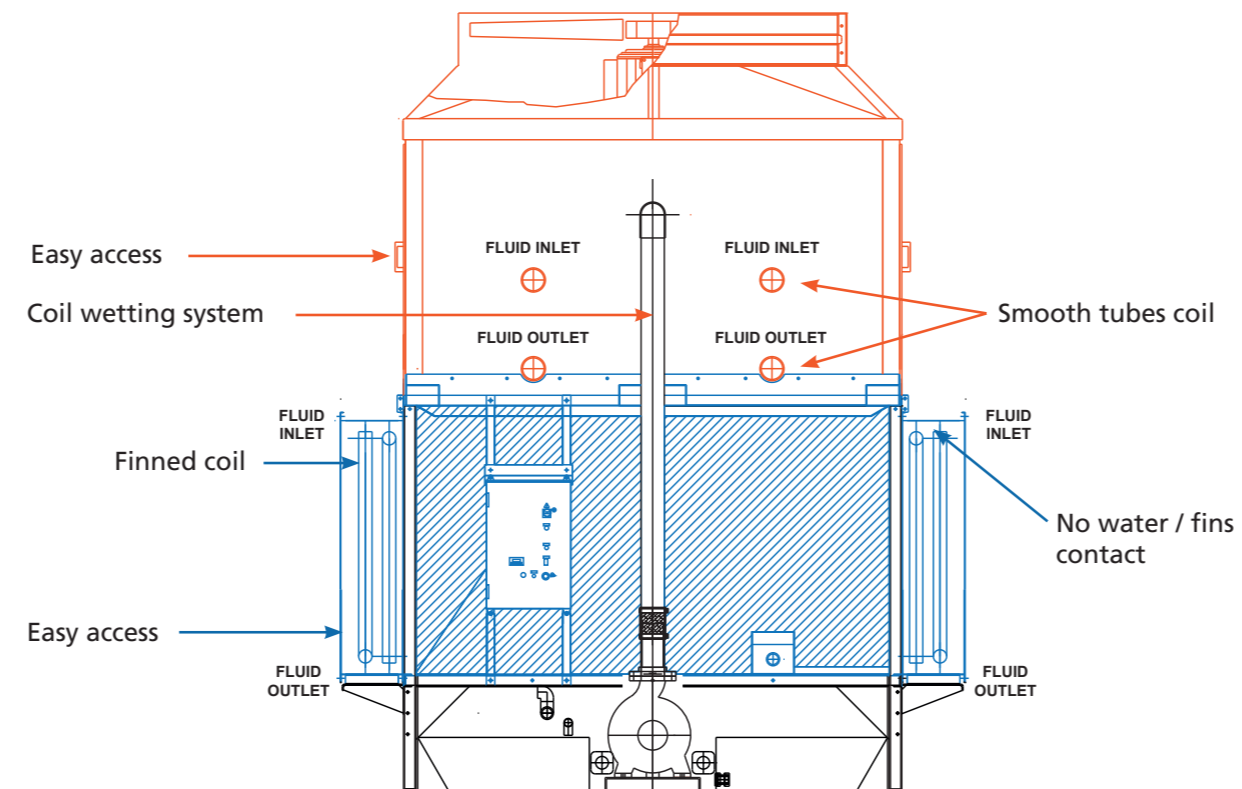

WINTER Air cooling function (dry mode)

- The fluid to be cooled flows inside the finned coils
- The spraying pump is OFF
- Axial fans in suction mode
- Smooth tubes coils in stand-by.

Evaporative Coolers

Evaporative Condensers

Hybrid Coolers

MCC-MCE-HBR
Series



MCC-MCE-HBR

MCC-MCE-HBR ENG • 09-17



Via Antonio M. Fontana, 1
Tel. +39 0382.67.599
www.mita-tech.it

I - 27010 Siziano (PV)
Fax +39 0382.617.640
e-mail: info@mita-tech.it



Evaporative coolers & condensers. MCC & MCE Series



■ Closed circuit evaporative cooling towers MCC Series

The MCC series closed circuit evaporative cooling towers are employed as an alternative to open-type cooling circuits with heat exchangers, in those cases in which the cooling fluid for the user's equipment (generally water or water with glycol) must maintain its chemical and physical characteristics constant over time and unpolluted by external elements. In fact the fluid to be cooled circulates within the tubes constituting the heat exchanger coil placed inside the cooling tower: the coil, in turn, is continuously wetted by the water contained in the basin of the tower, which is sent to a spray system with nozzles via the appropriate pump. Thanks to the combined effects of the evaporation of a small part of the spray water and of the turbulence created inside the tubes, the cooling of the fluid, which can hence be returned to the user's equipment, is achieved.



■ Evaporative condensers MCE Series

The MCE series evaporative condensers can be employed in air conditioning and industrial refrigeration installations, representing in their operation an alternative to the classical water-cooled condenser with evaporative cooling tower or systems with aircooled finned coils. The refrigerant gas to be condensed is fed to the upper header of a coil of smooth-surface tubes which, continuously wetted by water appropriately sprayed and in contact with an adequate countercurrent airflow, permits the progressive condensation of the gas. The gas, thus cooled and condensed to the liquid state, can be returned via the lower header to the installation. Hence the evaporative condenser, in the context of water-cooled condensing systems combines the "open circuit cooling tower condenser" system in a single and compact unit exploiting, inside the unit, the forced evaporation of a small quantity of the recirculating spray water to achieve the heat load rejection which is necessary to condensate the refrigerant gas.



■ Construction features

Fitted with one or more axial fans according to the model, the MCC and MCE series are built with a strong supporting structure in hot-dip galvanized steel and side walls made of fibreglass sandwich panels. The internal heat exchanger is composed of smooth-tube coils, fabricated in compliance with PED directive 2014/ 68/UE for MCE series only. The standard configuration is completed by the water collecting basin and the fan stacks made entirely of fibreglass (FRP).

The range includes several models suitable for installations with requested refrigeration capacities between approx. 80 and 1700 kW.

For all models several option items are available, such as:

- Different solutions to reduce sound emissions
- Totally removable side walls for an easy and total access to the internal parts, to simplify inspection, cleaning or maintenance operations
- Special dimensions for shipment by sea containers.



■ Fields of application

The closed circuit cooling tower is employed in industrial plants and civil air conditioning installations, in particular:

- cooling of delicate equipment such as air compressors, moulds and plastic extrusion machines, pipe-manufacturing (using an emulsion of anti-corrosion additive in the water of the closed circuit) or induction furnaces (with demineralised water)
- evaporative chilling (cooling tower's direct production of cold water for an air conditioning installation when the chiller is shutdown in the low season) and load shaving (direct production of cold water upstream of a chiller thus only subject to partload).

The evaporative condenser serving refrigeration plants can be employed in the following sectors:

- civil and industrial air conditioning installations
- industrial logistics
- refrigerated warehouses (e.g. storage of food products)
- industrial refrigeration.



Construction features

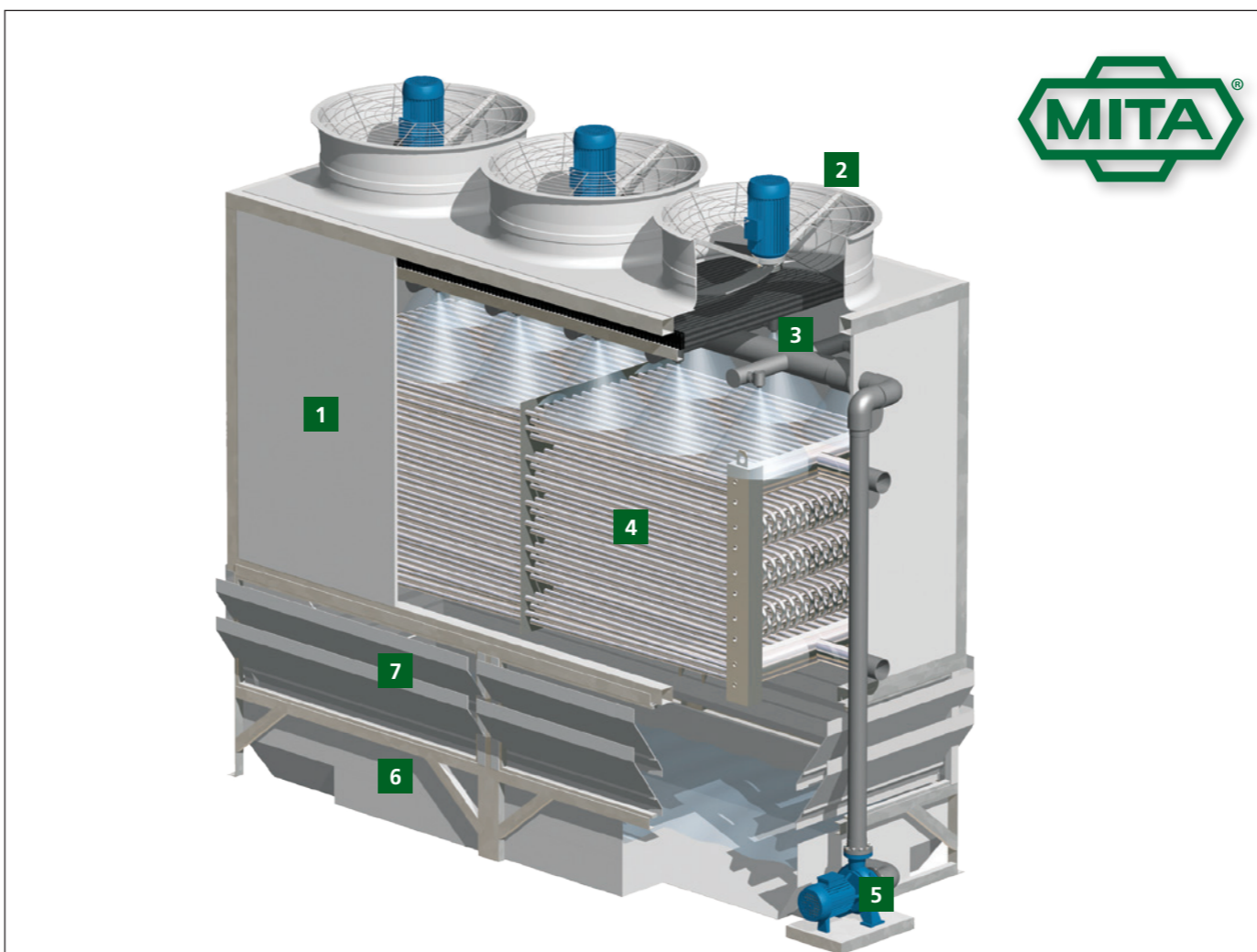

1 Structure and main casing

Construction Materials: steel supporting structure, hot-dip galvanised after fabrication, sandwich panelling in 22 mm thick fibreglass.

- Characteristics:**
- optimum mechanical resistance
 - good sound-absorption properties
 - non-corroding
 - easy internal inspection (with optional totally removable side walls).

2 Multi-blade axial fan

Construction Materials: hot-dip galvanised steel (support), plastic (fan blades), stainless steel (protective grid).

- Characteristics:**
- high performance, low absorbed electric power, fan directly driven by the motor
 - electrical wiring connections to fan motor/s.

3 Water distribution system

Construction Materials: normalised PN 10 PVC pipes, polypropylene tangential nozzles.

- Characteristics:**
- non-corroding
 - uniform and complete spraying of the coil, full-cone spray
 - exclusive MITA-design nozzles: the water flow is induced in the diffuser cone solely by the tangential connection to the main body of the nozzle, hence there are no internal parts which could cause obstructions.

4 Heat exchange coil (in compliance with PED directive 2014/68/UE for the MCE Series)

Construction Materials: hot-dip galvanised steel (stainless steel, on request for MCC Series).

- Characteristics:**
- large heat exchange surface
 - easy maintenance (thanks to the optional totally removable side walls).

5 Centrifugal water recirculating pump and piping of the spray water circuit

6 Basin with sloping bottom and top of the tower

Construction Materials: glass-mat reinforced orthophthalic polyester resin in several layers.

- Characteristics:**
- external surface protection by means of a gelcoat resistant to UV-radiation, to cold and hot water, to abrasion from the elements/weather conditions and to chemicals
 - internal water-proofing/impermeability obtained by means of an isophthalic, paraffin-containing, impermeable and hydrorepellent gel-coat (for the basin)
 - light-weight
 - non-corroding.

7 Anti-splash louvers on the air inlet openings

Construction Materials: PVC or fibreglass.

- Characteristics:**
- non-corroding
 - easy dismantling even after many years in service.

Dimensions and weights

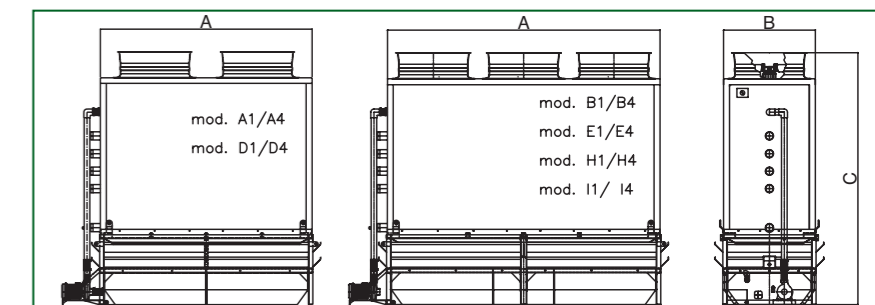

MCC-MCE Series

| TYPE | WEIGHT | | FAN | | PUMP | | | ELECTRIC HEATER* | | DIMENSIONS | | |
|----------|-----------|--------------|-----|-----------------|----------|----------|----|------------------|------|------------|-----------|--|
| | Empty kg | Operation kg | N° | Power kW (each) | Power kW | Flow l/s | N° | Power kW (each) | A mm | B mm | C mm | |
| A1 | 1130-1500 | 2530-2700 | 2 | 1,5 | 0,55 | 3,1 | 1 | 2 | 1870 | 1030 | 3160-3400 | |
| A2/A3/A4 | | | | 2,2 | | | | | | | | |
| B1 | 1530-2070 | 3200-3820 | 3 | 1,5 | 0,55 | 4,9 | 1 | 3 | 2770 | 1030 | 3160-3400 | |
| B2/B3/B4 | | | | 2,2 | | | | | | | | |
| D1 | | | | 2,2 | | | | | | | | |
| D2 | 1680-2380 | 3700-4400 | 2 | 3,0 | 0,75 | 6,0 | 1 | 3 | 2850 | 1235 | 3250-3480 | |
| D3/D4 | | | | 4,0 | | | | | | | | |
| E1 | 2030-2840 | 4680-5570 | 3 | 2,2 | 1,1 | 7,8 | 1 | 4,5 | 3670 | 1235 | 3250-3480 | |
| E2/E3/E4 | | | | 3,0 | | | | | | | | |
| H1/H2 | 2450-3440 | 5460-6600 | 3 | 3,0 | 1,1 | 9,6 | 1 | 4,5 | 3670 | 1505 | 3460-3700 | |
| H3/H4 | | | | 4,0 | | | | | | | | |
| I1/I2 | 2880-4220 | 6660-8130 | 3 | 4,0 | 1,1 | 12,0 | 1 | 7,5 | 4570 | 1505 | 3610-3875 | |
| I3/I4 | | | | 5,5 | | | | | | | | |

* optional

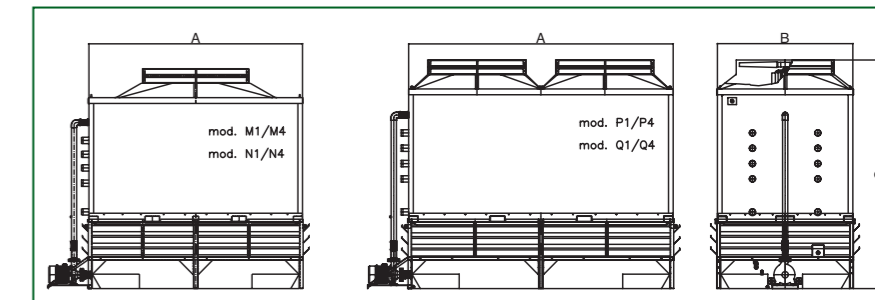

MCC-MCE Series

| TYPE | WEIGHT | | FAN | | PUMP | | | ELECTRIC HEATER* | | DIMENSIONS | | |
|-------|-----------|--------------|-----|-----------------|----------|----------|----|------------------|------|------------|-----------|--|
| | Empty kg | Operation kg | N° | Power kW (each) | Power kW | Flow l/s | N° | Power kW (each) | A mm | B mm | C mm | |
| M1/M4 | 2780-3950 | 6480-7800 | 1 | 11 | 1,1 | 11,9 | 1 | 7,5 | 2850 | 2340 | 3650-3890 | |
| N1/N4 | 3770-4820 | 8050-9660 | 1 | 15 | 2,2 | 15,4 | 1 | 7,5 | 3690 | 2340 | 3650-3890 | |
| P1/P2 | | | | 7,5 | | | | | | | | |
| P3/P4 | 4140-5980 | 9900-11900 | 2 | 11 | 3,0 | 19,3 | 2 | 5 | 4570 | 2340 | 3800-4030 | |
| Q1/Q4 | 4890-7180 | 11030-13500 | 2 | 11 | 4,0 | 23,2 | 2 | 7,5 | 5500 | 2340 | 3800-4030 | |

* optional

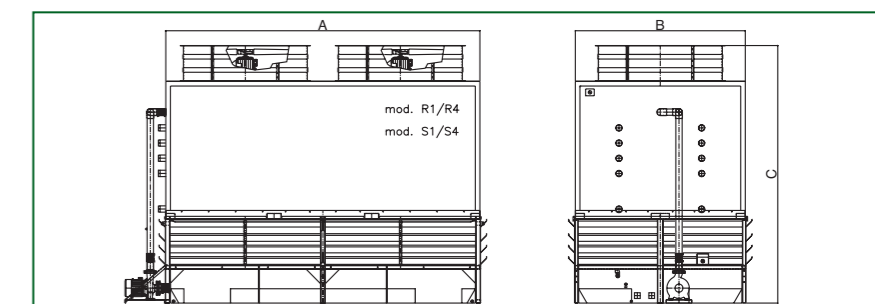

MCC-MCE Series

| TYPE | WEIGHT | | FAN | | PUMP | | | ELECTRIC HEATER* | | DIMENSIONS | | |
|----------|-----------|--------------|-----|-----------------|----------|----------|----|------------------|------|------------|-----------|--|
| | Empty kg | Operation kg | N° | Power kW (each) | Power kW | Flow l/s | N° | Power kW (each) | A mm | B mm | C mm | |
| R1/R2 | 5130-8470 | 11830-17080 | 2 | 11 | 4,0 | 24,5 | 2 | 7,5 | 4520 | 2960 | 4285-4560 | |
| R3/R4 | | | | 15 | | | | | | | | |
| S1 | | | | 11 | | | | | | | | |
| S2/S3/S4 | 5830-8470 | 14070-17080 | 2 | 15 | 4,0 | 29,4 | 2 | 7,5 | 5470 | 2960 | 4285-4560 | |

* optional

Technical data not binding, please contacts MITA Technical Dept. for full details

For dimensions and technical data of HBR Series, please contacts MITA Technical Dept.