



PMS K12

Open
cooling towers



PM Series - PMS with Diploma N° 16.02.002

MITA participates in the ECP programme for Cooling Towers. Check ongoing validity of certificate: www.eurovent-certification.com



PMS K12 SERIES COOLING TOWER

The PMS K12 cooling towers are built entirely in fibreglass (orthophthalic polyester resin, reinforced with several layers of glass fibre matting) in order to avoid corrosion problems due to the fact that the tower is constantly in contact with water and it is exposed to all kinds of weather.

The structure is self-supporting and strengthened at the points of greatest dynamic and static stress. Moreover, the fibreglass surface is protected by a gelcoat that is resistant to UV rays, hot and cold water and abrasion due to weather and chemicals.

The basin has a sloping bottom with rounded off corners, to enable an easy emptying to simplify its cleaning.

The filling material is made of self-extinguishing PVC with 12 mm flute.

The multi-blade axial fan (with blades in plastic material reinforced with glass fibre) grants high performances with low electrical power input and low noise levels.

The certified PMS K12 series includes 7 models, all available with or without water basin, for a range of cooling capacities from approx. 62 kW to 830 kW (indicative values referred to nominal temperatures conditions 40°C in, 30°C out, 24°C wet bulb).



ACCESSORIES AND CONSTRUCTION VARIANTS

The following accessories and/or construction variants are available for all models on request:

- three-phase heating element with control thermostat
- minimum level cut-out switch
- control panel
- manhole for easy inspection and access to the internal components.

Eurovent Certita Certification (ECC) & Cooling Technology Institute (CTI) together provide the international certification of cooling towers.

Performance certification is the basis for end-users, consultants, contractors, manufacturers and government to ensure correct investment in quality products.



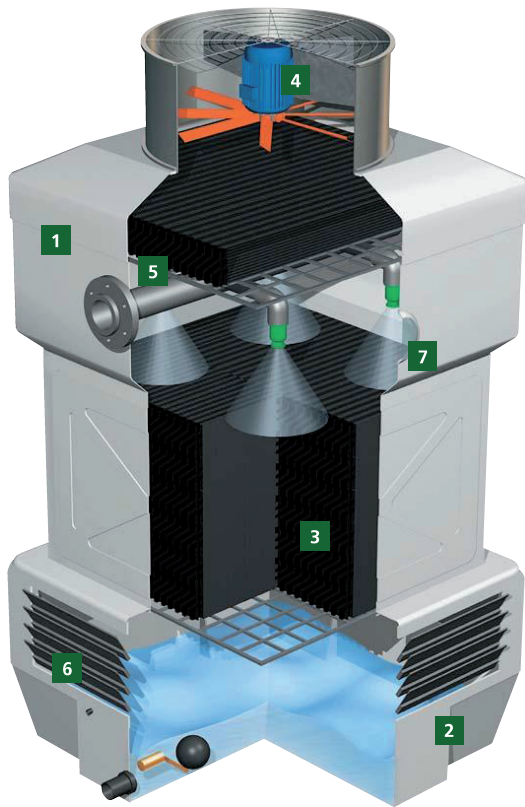

CONSTRUCTION DETAILS

1 Main casing and top cap

Material:

orthophthalic polyester resin, reinforced with several layers of glass fibre matting.

Characteristics:

- self supporting structure strengthened at the points of greatest dynamic and static stress
- external surface protection with gel-coating resistant to UV rays, cold and hot water, abrasion due to weather and chemicals
- light-weight
- non corroding.

2 Water basin (optional)

Material:

orthophthalic polyester resin, reinforced with several layers of glass fibre matting.

Characteristics:

- external surface protection with gel-coating resistant to UV rays, cold and hot water, abrasion due to weather and chemicals
- internal waterproof protection thanks to an impermeable, water repellent, paraffin containing orthophthalic gelcoat
- sloping bottom with rounded off corners, to enable an easy emptying to simplify its cleaning
- light-weight
- non corroding.

3 Filling material (or heat exchange surface)

Material:

self-extinguishing PVC.

Characteristics:

- 12 mm flute (air/water passage)
- reinforced top layer to better absorb dynamic stress caused by the under pressure sprayed water from the nozzles.

4 Multi-blade axial fan

Material:

motor support: hot dip galvanized steel (after all works), fan blades: plastic material, fan screening grid: stainless steel.

Characteristics:

- high performance, low electrical power input, low noise levels
- directly coupled to the electric motor
- unalterable safety over time thanks to the fan screening grid
- non-corroding.

5 Hot water distribution system

Material:

PN 10 unified PVC, PP, PE pipes, polypropylene nozzles.

Characteristics:

- non-corroding
- uniform and total spraying of the heat exchange filling pack
- MITA exclusive nozzles design, with non-clogging wide passages for a full cone spray.

6 Anti-splash louvers on air intake openings

Material:

fibreglass louver (on request: PP panels in a suitable galvanized steel frame).

Characteristics:

- non corroding
- easy to remove even after many years of use.

7 Visual inspection window

Material:

nylon reinforced with glass fibre

8 Bolts, nuts and washers

Material:

stainless steel 304.

Characteristics:

- non corroding
- easy to remove even after many years of use.



PM Series - PMS with Diploma N° 16.02.002

MITA participates in the ECP programme for Cooling Towers. Check ongoing validity of certificate: www.eurovent-certification.com



PMS K12 Series with water basin

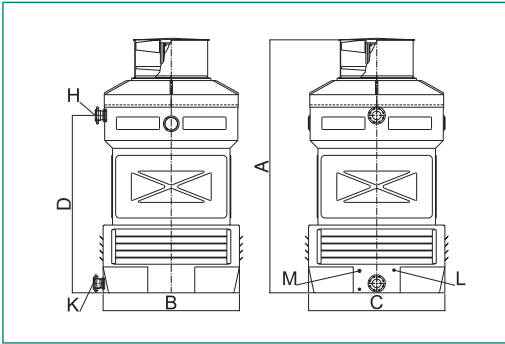

PMS K12 Series without water basin

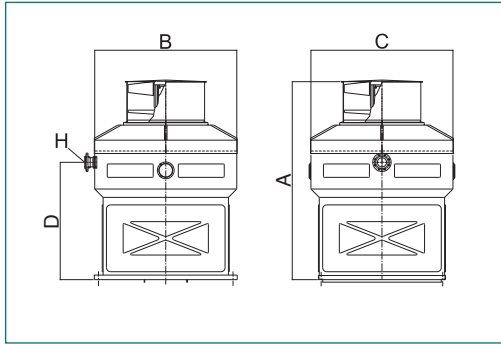

DIMENSIONS AND WEIGHTS

Model	Dimensions				Water connections				Nominal water flow rate*	Total nameplate fan motor power per model*	Total rated fan motor power per model*	Weights	
	A	B	C	D	H	K	L	M				empty	in operation
	mm	mm	mm	mm	Ø in	Ø in	Ø in	Ø in				kg	kg
with water basin													
PMS 6/65 K12	2190	800	800	1500	2"	2"	3/4"	1/2"	1,5	1,1	0,89	75	180
PMS 9/85 K12	2695	1000	1000	1900	2 1/2"	2 1/2"	3/4"	1/2"	3,4	2,2	1,68	95	285
PMS 9/110 K12	2870	1200	1200	2000	3"	3"	1"	3/4"	5,6	3	2,17	170	485
PMS 9/130 K12	2935	1400	1400	1900	4"	4"	1"	3/4"	7,9	4	3,52	210	780
PMS 10/180 K12	3200	1740	1740	2060	4"	4"	1 1/4"	1"	12,4	5,5	4,51	410	1410
PMS 10/240 K12	3515	2100	1900	2240	4"	5"	1 1/4"	1"	15,9	7,5	6,44	525	1825
PMS 10/260 K12	3530	2300	2100	2250	5"	6"	1 1/2"	1 1/2"	19,9	7,5	6,82	580	1980
without water basin													
PMS 6/65 K12	1670	770	770	990	2"	-	-	-	1,5	1,1	0,89	60	80
PMS 9/85 K12	2025	980	980	1230	2 1/2"	-	-	-	3,4	2,2	1,68	75	100
PMS 9/110 K12	2240	1215	1215	1385	3"	-	-	-	5,6	3	2,17	135	185
PMS 9/130 K12	2270	1370	1370	1270	4"	-	-	-	7,9	4	3,52	165	225
PMS 10/180 K12	2335	1715	1715	1230	4"	-	-	-	12,4	5,5	4,51	325	440
PMS 10/240 K12	2485	1805	2050	1235	4"	-	-	-	15,9	7,5	6,44	430	535
PMS 10/260 K12	2550	2010	2210	1270	5"	-	-	-	19,9	7,5	6,82	490	600

* Nominal temperature conditions: 40°C in; 30°C out; 24°C wet bulb.

Technical data not binding

For data concerning other versions, please write to: export@mitact.it

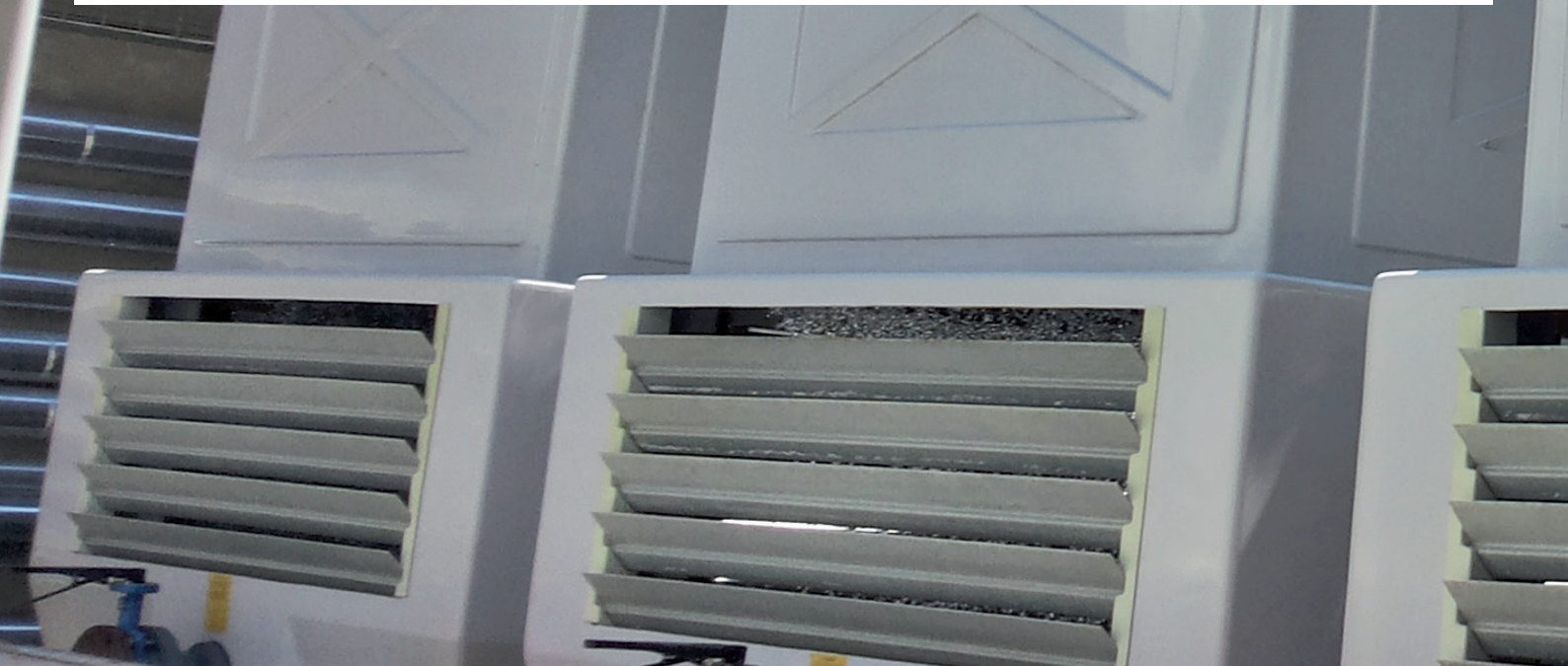

Via del Benessere, 13
27010 Siziano (PV) - Italy
+39 0382.67599 - info@mitact.it